

Products for public transport



voyager® 



Press Announcement



NEW PRODUCT

**ATLAS POI
TOUR GUIDE**



Point of Interest – Infotainment for Passengers



Atlas POI System – Sightseeing Tour Guide



ATLAS POI SYSTEM



ATLAS POI SYSTEM



Atlas POI System – Sightseeing Tour Guide

- **1 DIN size** head unit, combined GPS receiver and POI Database
- On specific POI, an Audio or Video information given to passengers automatically without interaction from the driver.
- Used to enhance and enhance the passengers information on POIs in EU and D
- Currently available in German command only , others to follow by request
- Works independent on every coach as plug an play solution, simple connectivity
- Fixed and portable version available (Cigarette lighter connection)



ATLAS POI SYSTEM



Atlas POI System – Sightseeing Tour Guide

- Connectivity to match coach infrastructure to add feature without big installation
- Works on 24-36 Volts systems
- EU - USB Data Stick contains 2100 POI
- D - USB Data Stick contains 1000 POI
- POI Database supplied from German POI provider, incl. Brown Highway Signs
- ATLAS can be customised to match specific Route requirements
- Based on Dension Voyager product line, fully digital structure



ATLAS POI SYSTEM



ATLAS Connection Interface

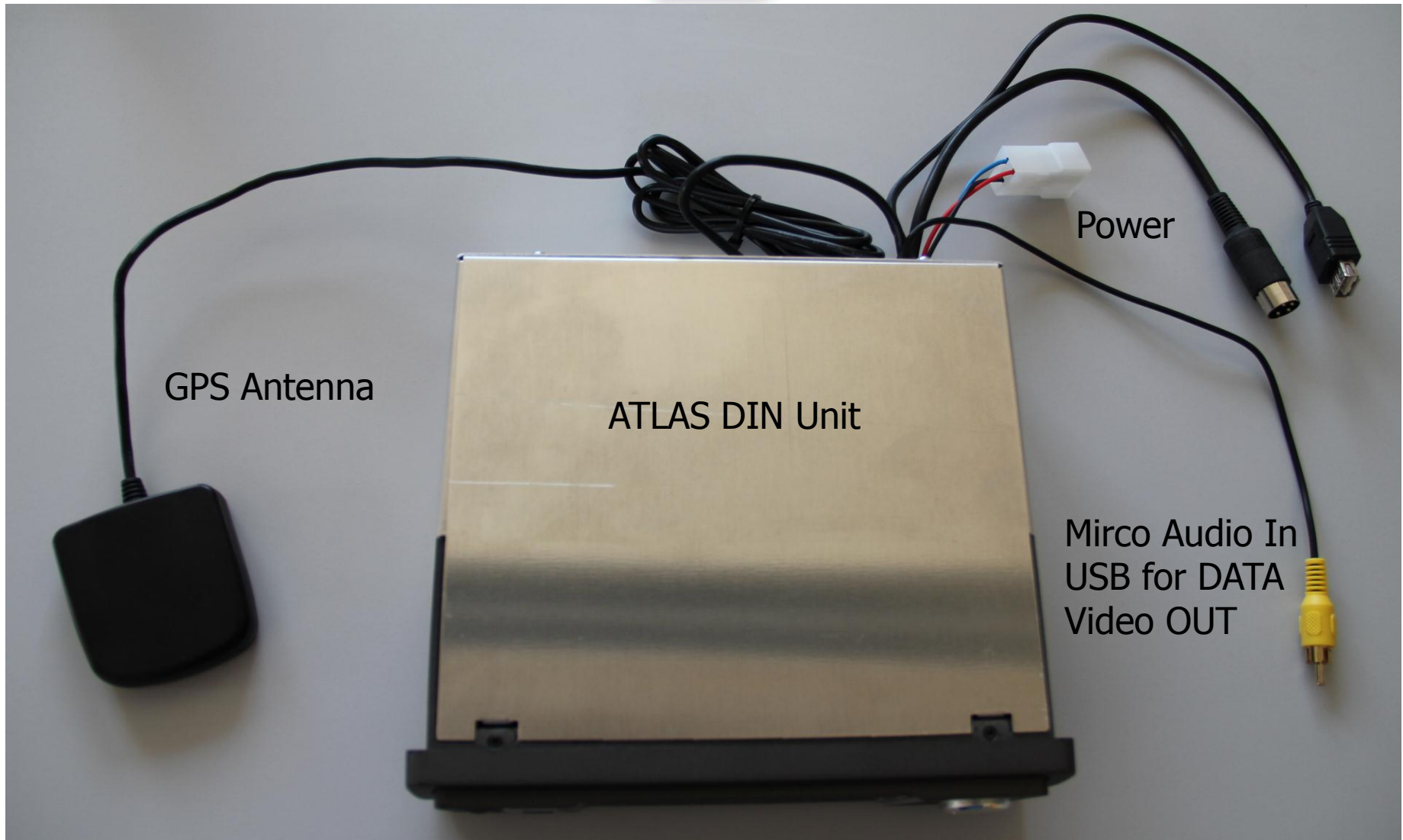

ATLAS Accessories



ATLAS Audio Interface

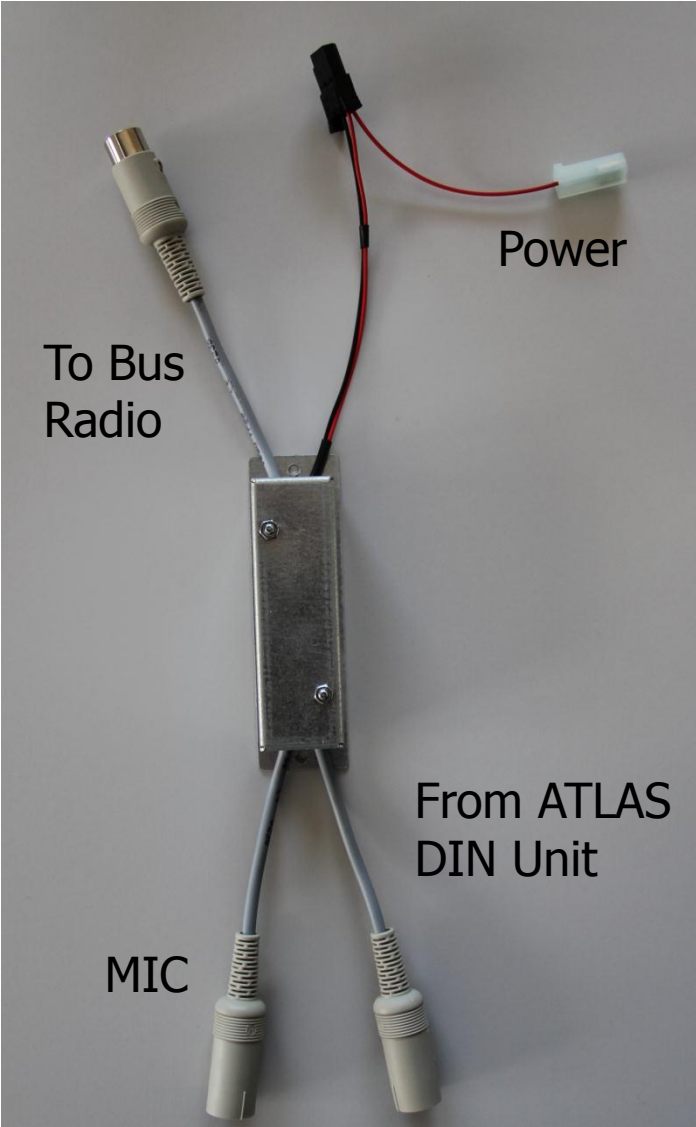

ATLAS Accessories



ATLAS Video Interface

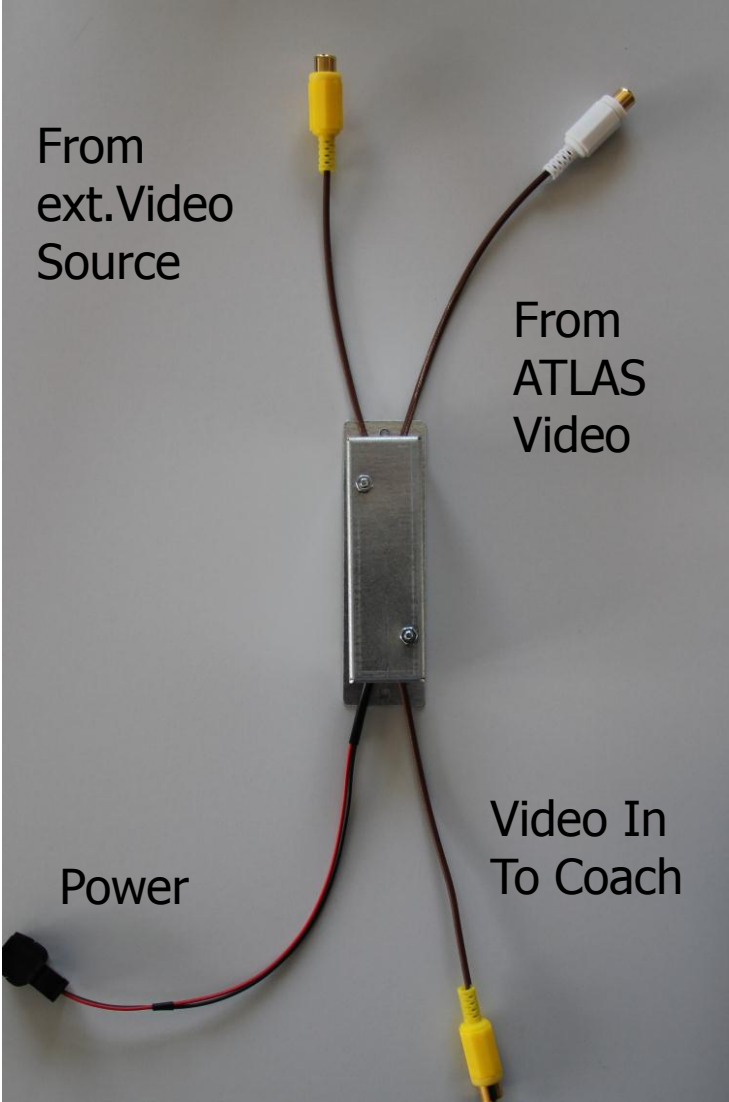

ATLAS Accessories



**ATLAS
ON/OFF
Switch for
Driver**



What is Voyager?



- **Digital** Passenger Infotainment System developed for public transport vehicles
- High speed, electrical network, in ring topology, using a single twisted pair for data communication, 1 wire for wake-up and 2 wires for power feed

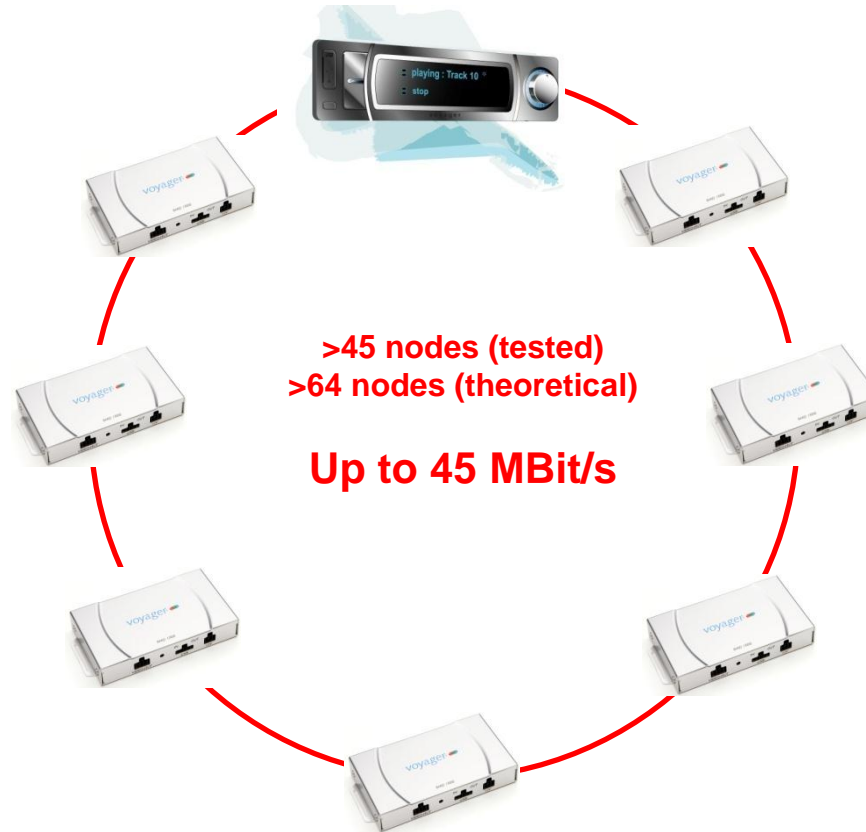

System elements – DMS1200



DMS1200 - Digital Media Server

- **1 DIN size** head unit, easy to fit in driver's console
- **Customer dedicated** entertainment, fleet operator decides what is being shown to passengers, the driver has no influence on that (e.g. commercials are compulsory to show)
- **Simple HMI** for the driver to control the system
- Front USB connector for inserting the dedicated Voyager memory stick to feed the system with content digitally
- Connection for **two push-to-talk microphones**, one for the driver and one for e.g. the tour guide (no need for additional control box)
- **AUX IN** for streaming any type of content by drivers (from e.g. iPod)



System elements – VPM-08 Portable Media



VPM-08 - Portable Media

- **Solid-State memory** provides reliable operation over long period of time
- Different capacities (**8-16-32 GByte**)
- **Unique instertion** guides designed for eyes free handling by driver
- **Low cost / Gigabyte memory** due to ongoing price decay led by high consumer demand for low cost memories
- Memory capacity demands:
 - Elite: 1hour video=2GBytes



System elements – RMD1000



RMD1000 – Roof Mounted Displays

- Video stream decoder with 3 built-in video amplifiers for direct **connection of 3 screens** via short analogue link
- Connection with displays via **digital** 24 bit CMOS LCD interface (**RGB**) guarantees best quality for digital video as no signal conversion is needed
- **SD** (720x576) **resolution (4:3 aspect ratio)**
- **Full HD** (1920x1080) possible on demand
- **Dynamic Resizing** will match LCD Native resolution for best passenger viewing
- **Competitive Sourcing** - standard analogue link enables coach makers to take advantage lowest commodity price
- **Service Differentiator** - Fleet Operators get the performance they needed to attract more customers



System elements – RMS1000



RMS1000 – Roof Mounted Speakers

- Audio stream decoder with 2 built-in audio amplifiers for direct **connection of 2x4Ω, 4x8Ω (in parallel) speakers** via short cable (4 speakers in parallel)
- **CD quality** sound for every passenger
- Free **configuration** of Volume-, Treble- and Bass level, module by modules (e.g. to set higher volume for passenger sitting close to the engine)
- **50W Output** (PMPO at RL 4 Ω) provides excellent performance at any position in the vehicle
- **Automotive grade Microfit 3.0 connectors**

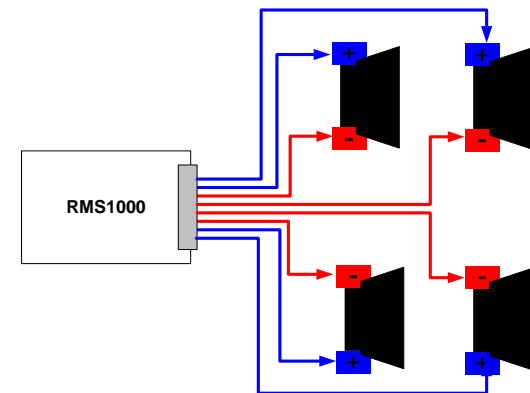

System elements – PSM1000, PRC1000



PSM1000 – Passenger Seat Module

- **Audio stream decoder** with 3 built-in head phone amplifiers for direct connection of **3 PRCs**
- **Automotive grade Microfit 3.0 connectors**



PRC – Passenger Remote Control

- **3,5 JACK** connector for head phone
- **CD quality, stereo sound** for every passenger
- Program +/- and Volume +/- control
- 2x7-Segment LED display
- Water-resistant housing
- Scratch proof plastic window



Technical Specification



Temperature

- Operating temperature range: -40C ... +70C
- Storage temperature range: -40C ... +85C

Compliance

- e24-marking (ECE-10R regulation, 72/246/EEC, last amended by directive 2006/28/E)
- ROHS

Mechanical Vibration

- Sine vibration up to 3G between 5Hz...100HZ
- Mechanical shock

ESD (Electrostatic discharges)

- Packaging, handling: up to 8KV AD (air discharge)
- Powered, operational : up to 4KV AD ,CD (contact discharge)

Electrical

- Standby current < 1mA on all modules
- Short circuit protection
- Overheat protection
- Immunity to supply line (generator) noise

Main reasons to select Voyager Family



Digital system

- Better video quality compared to the traditional analogue systems (Short RCA cable, HD, RGB)
- Same audiovisual experience for each passenger, independent from its position in the coach
- Less electrical noise sensitivity
- Software update in 3 Minutes centrally from the DMS1200 for the complete system
- Free configuration of Volume-, Bass-, Treble level, delays for the individual modules (Audio and video)

Build flexibility, modularity

- Less weight/more passenger = GREEN
- Unlike traditional analogue system (star topology), Voyager is a simple installation (ring topology), simple to replace the individual modules
- Can be extended to double or triple decker coaches without an exponential increase of the cabling
- Number of speakers, displays, head phones can be free configured
- Maximum number of nodes:
 - 45 (tested): 90x4Ω Speakers-180x8Ω Speakers, 135 Displays, 135 Head phones
 - 64 (theoretical): 128 Speakers, 192 Displays, 192 Head phones

Customer Use Case : SSB, Stuttgart



Stuttgart Tour gestartet

Stuttgart mit dem Bus erkunden – das können seit Freitag, 1. April die Besucher der Landeshauptstadt und Stuttgarter Bürgerinnen und Bürger. An diesem Tag startete das tägliche Hop-on-Hop-off-Angebot der Stuttgarter Straßenbahnen AG (SSB). Die Stuttgart-Stuttgart Tour verbindet die wichtigsten Sehenswürdigkeiten Stuttgarts.

Bequem und komfortabel werden die Gäste durch Stuttgart **gefahren und werden ein Audio-Guide über die Sehenswürdigkeiten in zehn Sprachen informiert.**

Customer Case SSB Review



Requirements at SSB:

- Audio distribution on every seat in the Bus
- High Quality Audio in 10 Languages simultaneously
- Interrupt at Point of interest (POI) needed
- Bullet proof System for operation 18h/7days
- Flexible update of new POI's

Dension Solution

- Voyager Elite System for 3 Coaches with each 55 Seats
- Update of Firmware to enable GPS Position data
- GPS Receiver with modified USB connection to Voyager Headunit
- Proven software Playlist Manager to manage POI Data
- Easy to use protected USB Mass Storage to be used to host POI Data for the system

Financial and operational benefit

- SSB have a unique selling point for tickets on Sightseeing to support 10 languages
- Can be changed quickly to adopt new POI settings
- Return on invest of whole system manageable within months according to SSB
- New Bus operations will be launched very soon.

Internet in the Vehicle – HOTSPOT in Coach



Internet in the Vehicle – HOTSPOT in Coach



Connections on Dension Wi-Drive



2 x Wi-Fi Antennas



To Car USB

USB Mass
storage Device

2xUSB extensions
UMTS/3G Modem

Push button

LED indicators

Comfort Feature: Internet HotSpot



WI-FI HotSpot to support:

- Each Seat an WI-FI connector
- Internet access for iPad, Tablet PC, Game Consoles
(Carrier depended)
- Wireless Network to allow Infotainment for passengers
- In combination with other devices such as Apple TV



Implementation: Internet HotSpot



Easy Internet access through

- 3G modem (USB dongle), **or**
- 3G Industrial Modem

Wi-Fi Antenna installed in the vehicle

Power supply from the vehicle

- Continuous 12V for power supply
- Switched 12V for power management

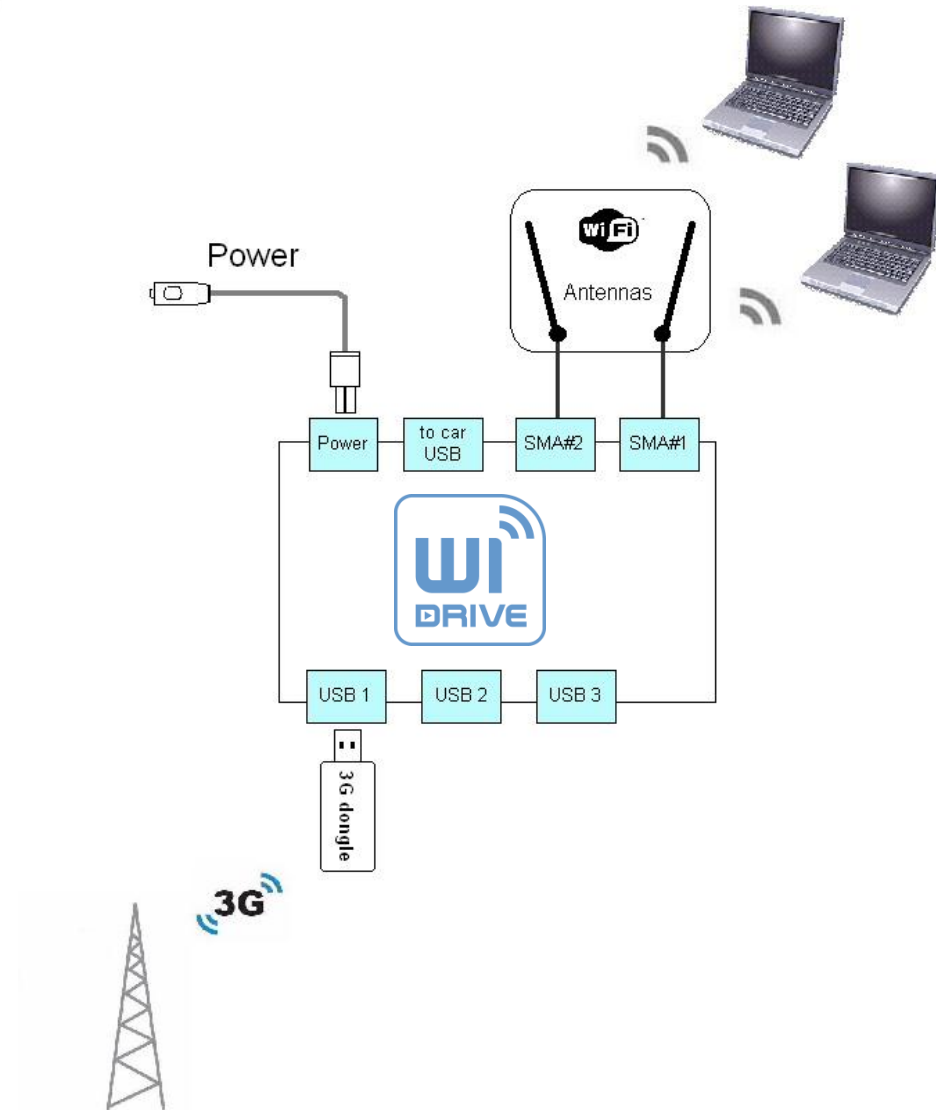

Implementation: Internet HotSpot



Advantages

Automotive Power Management

- Standby current < 100 μ A
- Battery level monitoring
- Switch on/off control by the switched 12V line

No need for separate internet subscription

- 3G USB Modem dongle **or** Industrial 3G Modem (Accessories)

Plug & Play installation

Up to **8 Users** in parallel can be served to guarantee solid download speed

Possibilities for Individualisation



- 10 to 36 Volt Operation
- Building in a 3G/LTE modem and using external antennas, specific
- Data Traffic Control
- Dual SIM and complex Data Management
- Including an automotive HDD or SSD to enable NAS Server, APPLE TV
- Integrating other (than 3G dongle) applications on the USB port of Wi-Drive
- Changing HMI
- Branding of plastic Molding
- Adjustments to technical specifications

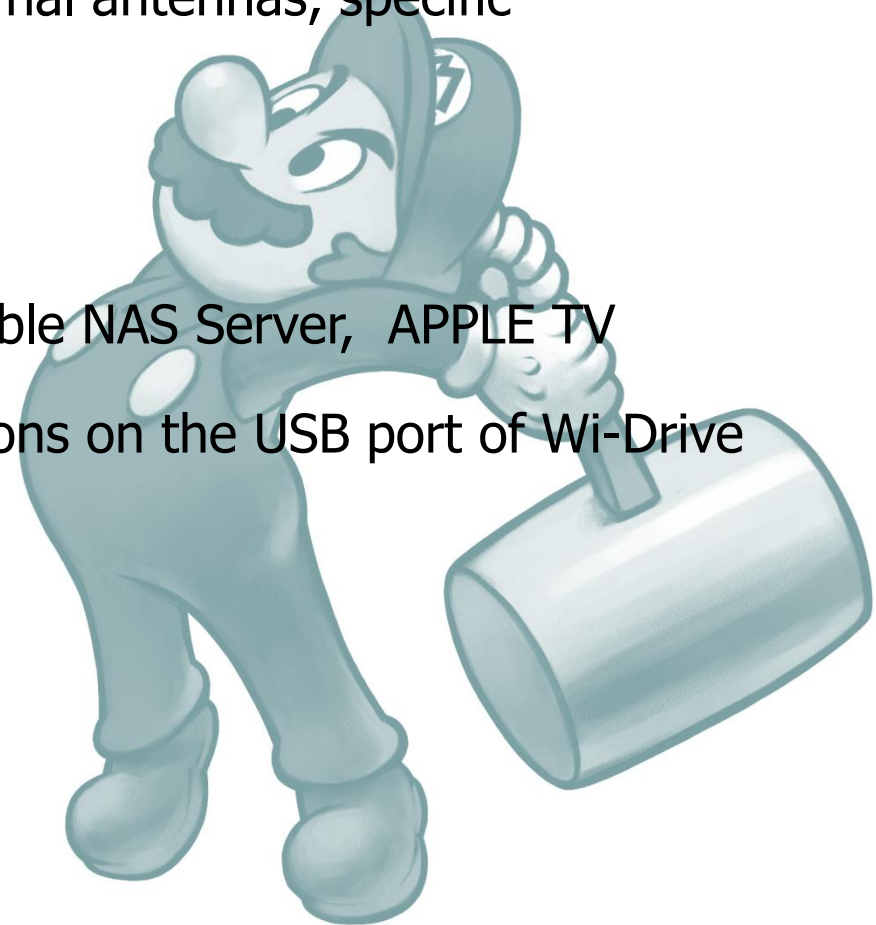

Thank you for your attention



DENSION
Public Transport

www.densionpublictransport.com

